

MARK	REVISIONS NO	REASONABLE RVISIONS	DATE	DWN	APVD

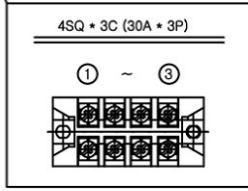
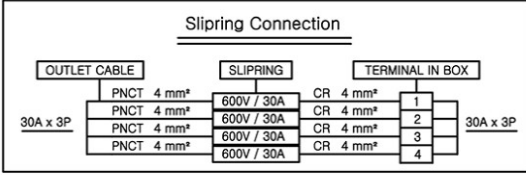
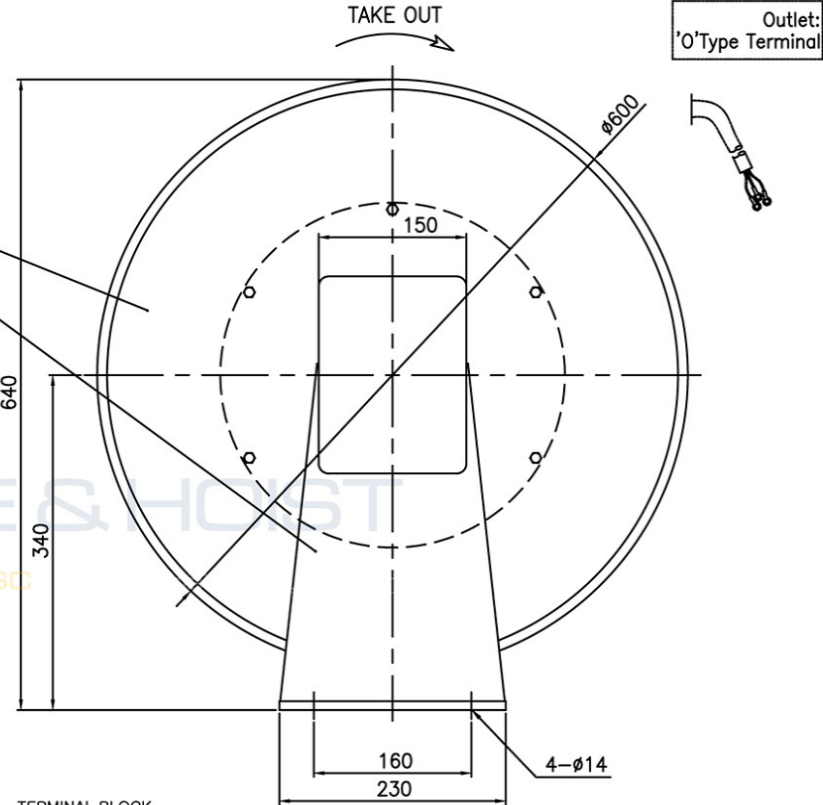
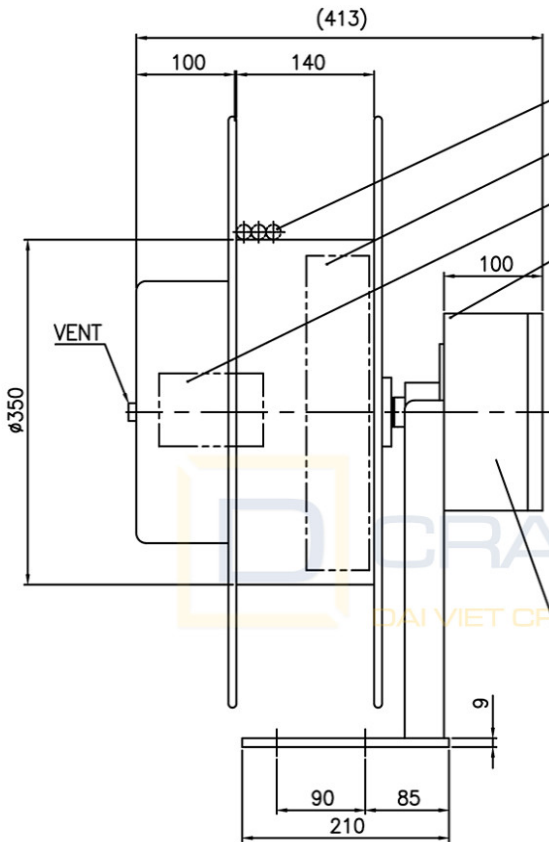
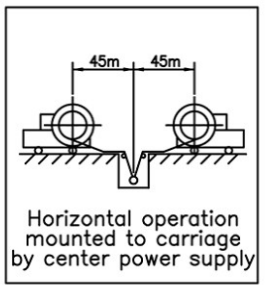
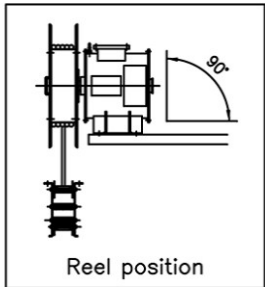
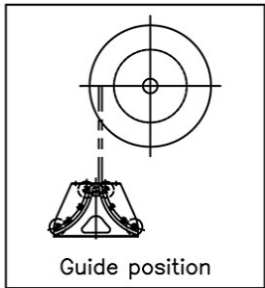

SPECIFICATION

- 1. Cable
 - o PNCT 4 sq x 3c
 - o Size : approx. Ø14.3mm
 - o Weight : approx. 0.323 kg/m
 - o Length : 50 M
- 2. Winding Length : 45 M
- 3. Winding Speed : max. 20 M/MIN
- 4. Winding Torque : 1.5 Kg.m
- 5. Slip Ring : 30A x 3P
- 6. Paint Color : MUNSELL No. 7.5 BG6/1.5,60um,Out Door
- 7. Setting Height : Max. 1 m from G.L.
- 8. Q' ty : 1 Set

6	-	FRAME ASS'Y	SPHC	1	
5	-	DRUM ASS'Y	SPCC	2	
4	-	TERMINAL BOX	PLASTIC	1	
3	-	SLIP RING	C3771	3	
2	-	SPRING	ATX	4	
1	-	CABLE	PNCT	50M	
ITEM	PARTS NO.	PART NAME	MATERIAL	Q'TY	REMARKS
순번	품번	품명	재질	수량	비고

PROJECTION	DIMENSIONS	SCALE	MODEL
3rd ANGLE	METRIC (mm)	1 : 8	ECC-450-3-R
CUSTOMER	PART NAME		ASS'Y
MODEL COLOR	PART NO.		Z829-8000
DRAWING	DESIGN	CHECK	APPROVAL
SIGN	P.S.Y		
DATE	2017.3.10		

KOREEL
SAMKOOK INDUSTRIAL CO., Ltd

A4(210X297)